

# Plastic design with HSS beams

---

Design requirements for the application of plastic design of beams made of high strength steel

# Plastic global analysis



<https://havitsteelstructure.com/steel-structure-detail/>

# Plastic Design in EC 3-1-1

## Cross-section requirements for plastic global analysis EC 3-1-1 – Section 5.6

- Class 1 cross-section

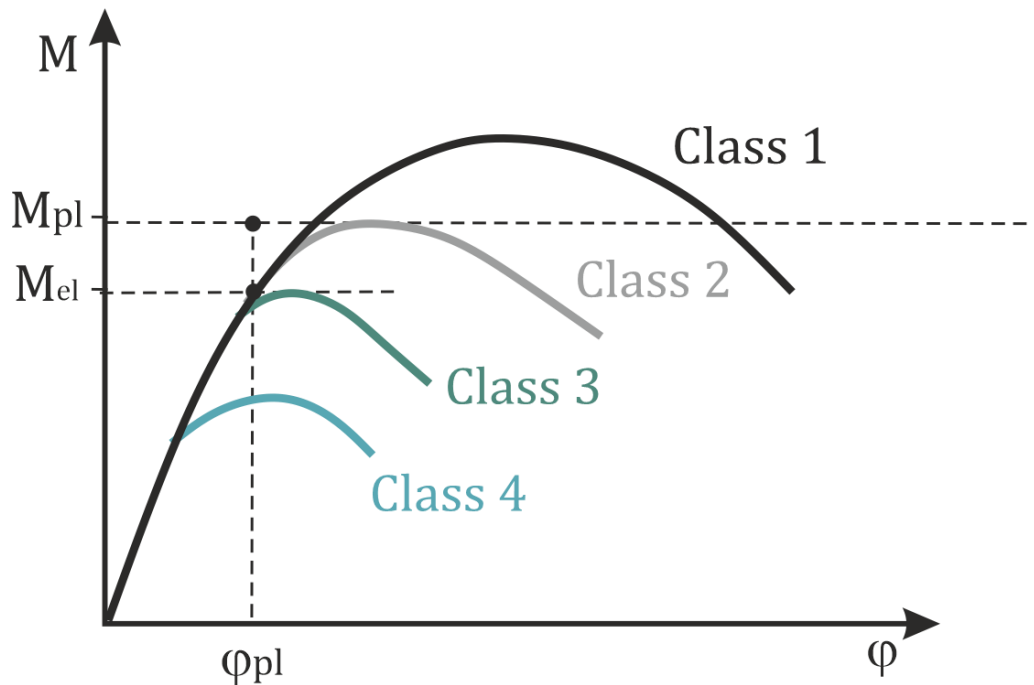

# Plastic Design in EC 3-1-1

## Cross-section requirements for plastic global analysis EC 3-1-1 – Section 5.6

- Class 1 cross-section

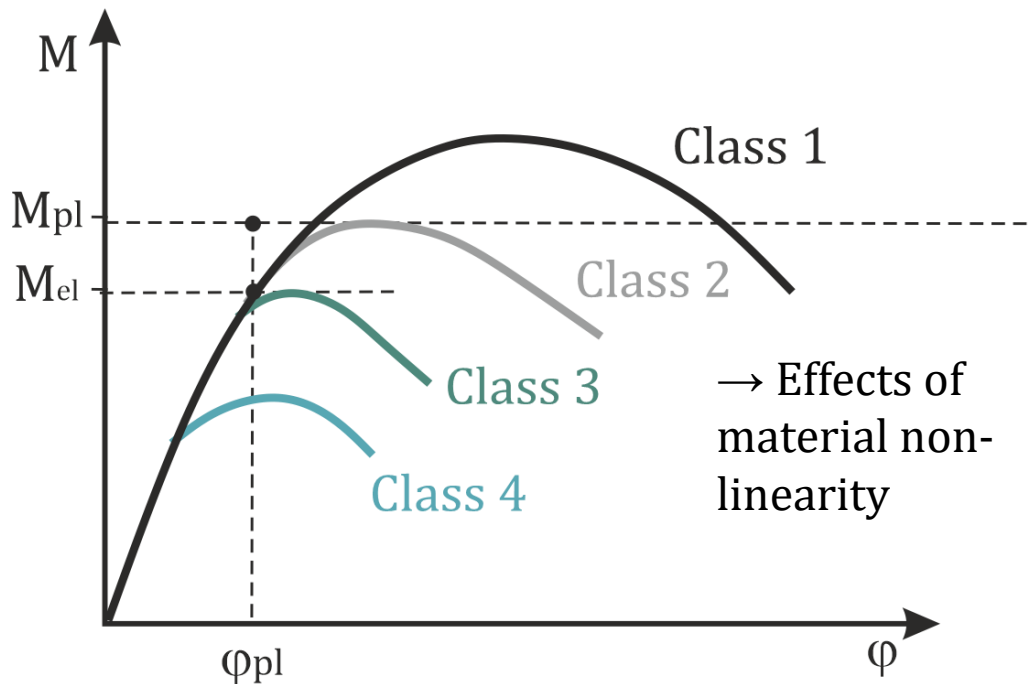

EC 3-1-1 / EC3-1-12:

Plastic global analysis can be applied for conventional strength steel, **not for high strength steel.**

→ **STROBE-Project**

# Plastic global analysis

EC 3-1-1 – Section 5.4.3

- Allows for effects of material non-linearity when calculating action effects

Example: Formation of plastic collapse mechanism

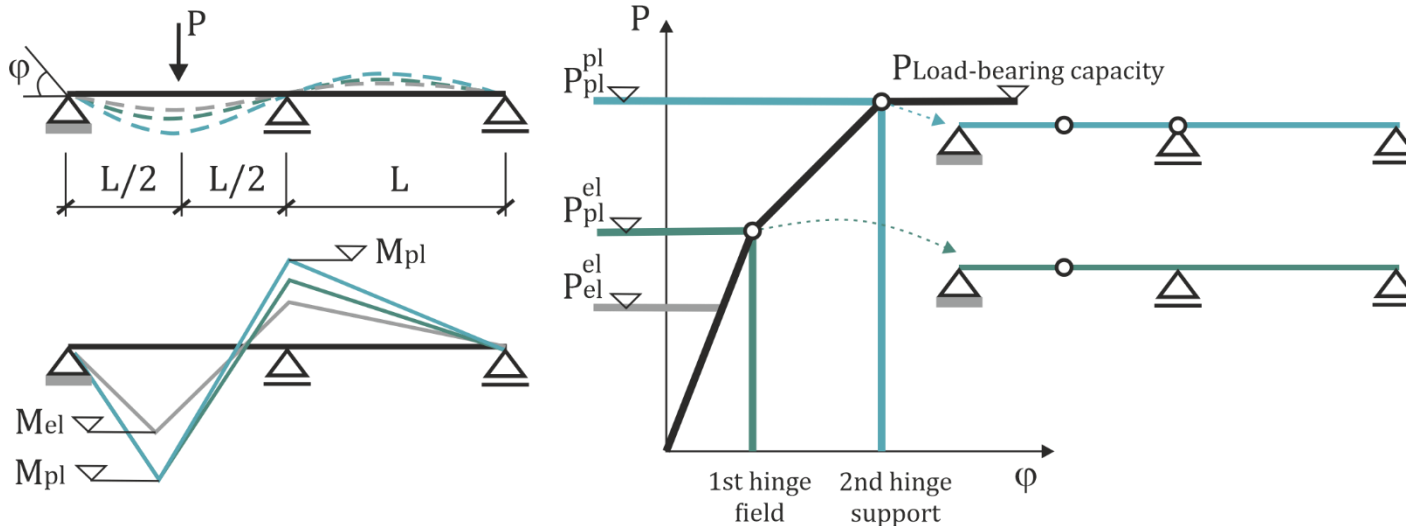

# Plastic global analysis

EC 3-1-1 – Section 5.4.3

- Allows for effects of material non-linearity when calculating action effects

Example: Formation of plastic collapse mechanism

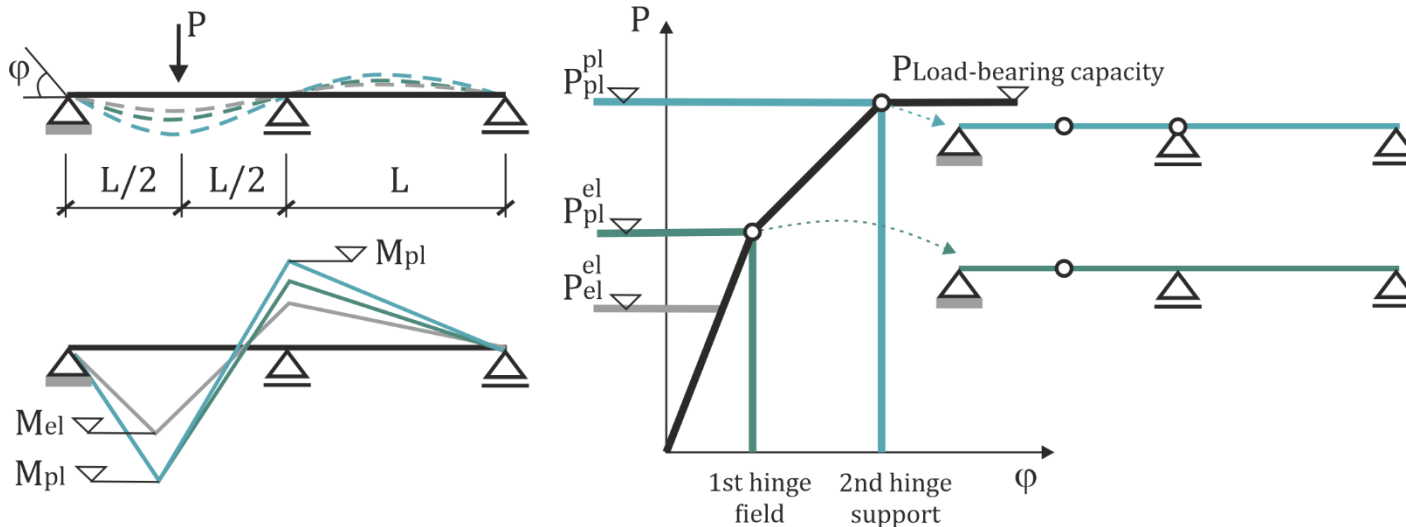

- Realistic determination of load bearing capacity → More economic design

# Plastic global analysis

EC 3-1-1 – Section 5.4.3

- Allows for effects of material non-linearity when calculating action effects

Example: Formation of plastic collapse mechanism

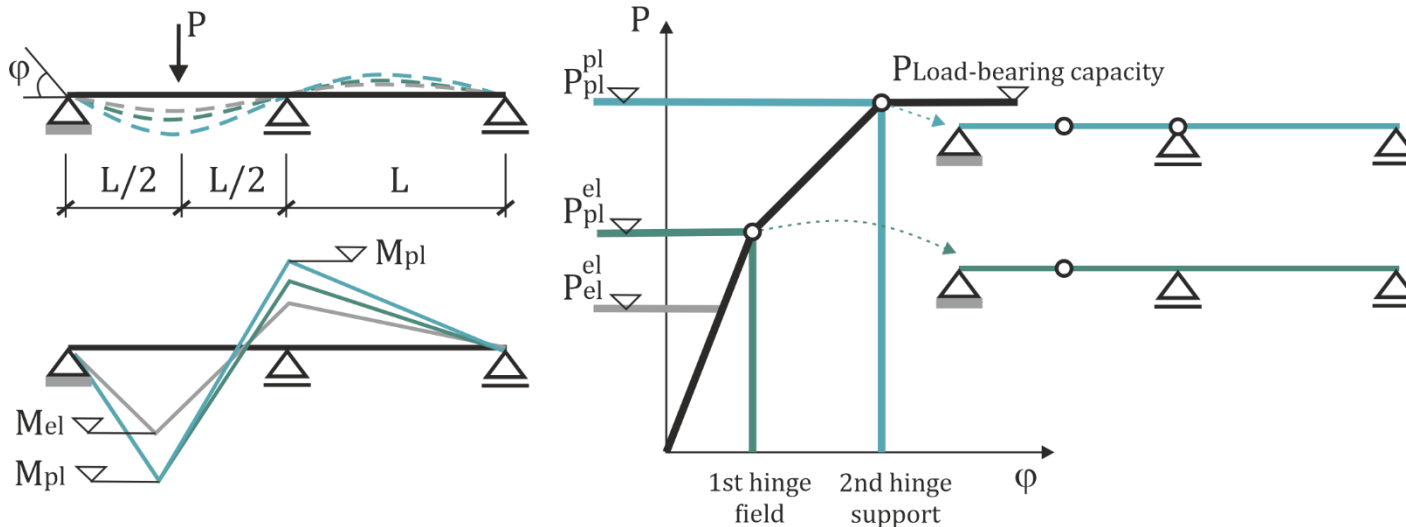

- Realistic determination of load bearing capacity → More economic design
- Stability of members has to be guaranteed EC 3-1-1 – Section 6.3.5

# Plastic global analysis

EC 3-1-1 – Section 5.4.3

- Allows for effects of material non-linearity when calculating action effects

Example: Formation of plastic collapse mechanism

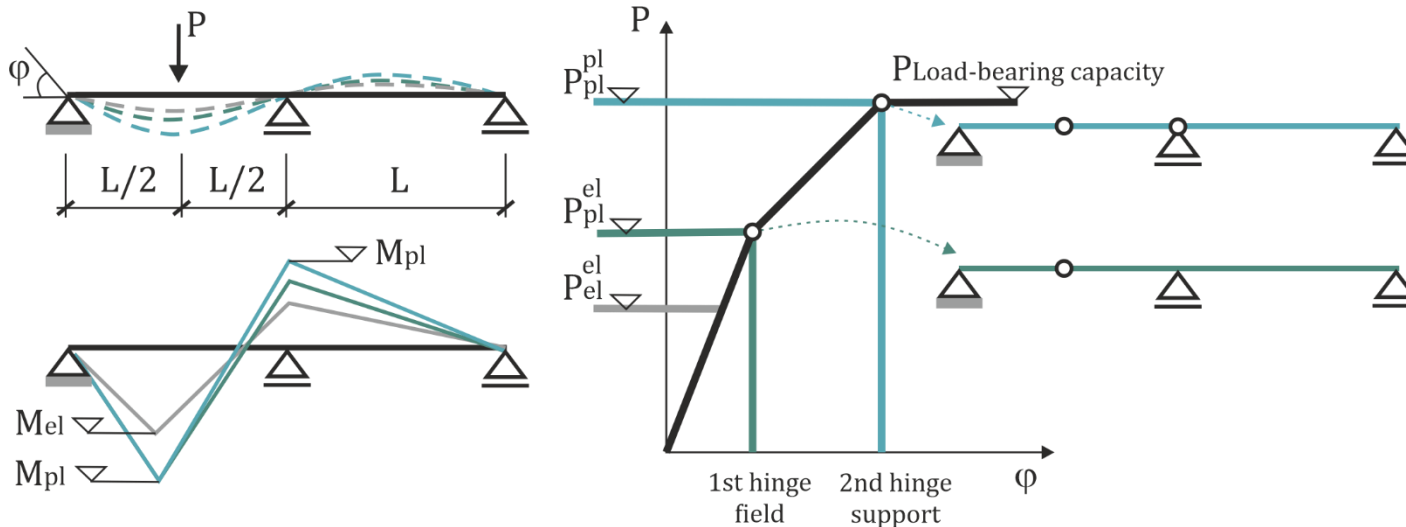

- Realistic determination of load bearing capacity → More economic design
- Stability of members has to be guaranteed EC 3-1-1 – Section 6.3.5
- A sufficient **rotation capacity** of the members has to be ensured EC 3-1-1 – Section 5.6

# Plastic Design in EC 3-1-1

## Cross-section requirements for plastic global analysis EC 3-1-1 – Section 5.6

- The member has Class 1 cross-sections:

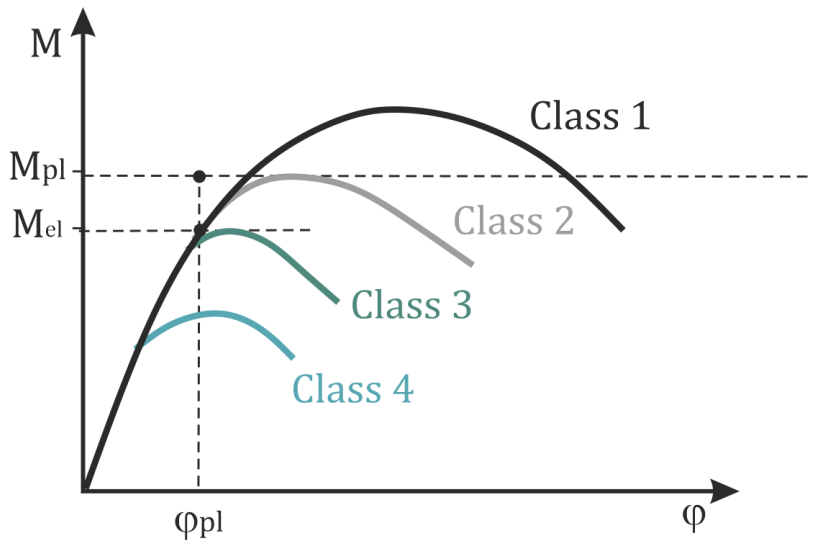

- Additional regulations referring to application of stiffeners, fastener holes, etc.

Web

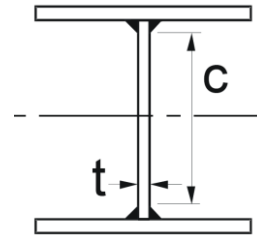

Class	Part subject to bending
Stress distribution in parts (compression positive)	
1	$c/t \leq 72\varepsilon$

$$\varepsilon = \sqrt{\frac{235}{f_y}}, f_y \text{ in } \frac{N}{mm^2}$$

# Plastic Design in EC 3-1-1

## Cross-section requirements for plastic global analysis EC 3-1-1 – Section 5.6

- The member has Class 1 cross-sections:

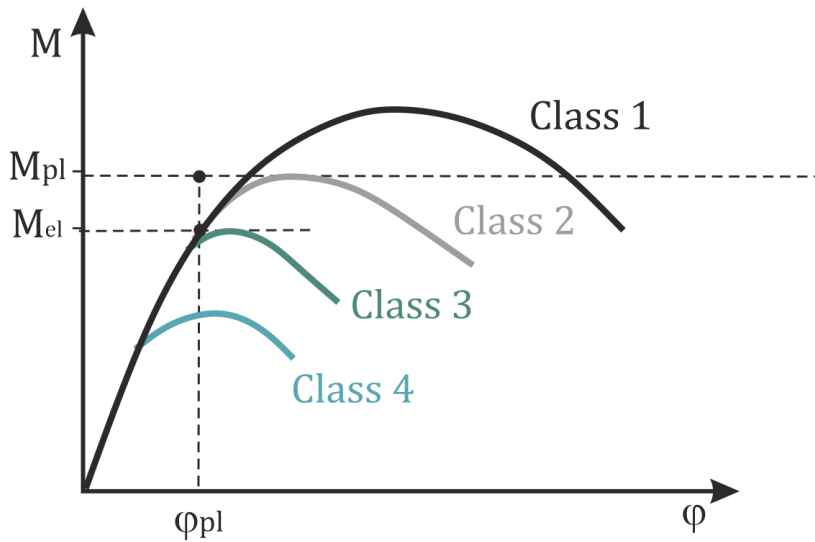

- Additional regulations referring to application of stiffeners, fastener holes, etc.

Web

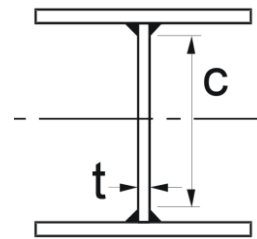

Flange

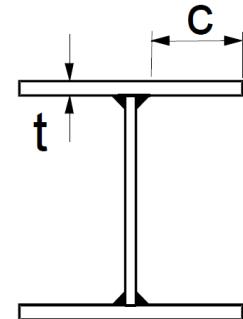

Class	Part subject to bending
Stress distribution in parts (compression positive)	
1	$c/t \leq 72\varepsilon$

Class	Part subject to compression
Stress distribution in parts (compression positive)	
1	$c/t \leq 9\varepsilon$

$$\varepsilon = \sqrt{\frac{235}{f_y}}, f_y \text{ in } \frac{N}{mm^2}$$

# Definition of Rotation Capacity

## Rotation Capacity

- Class 1 members of CSS show a sufficient **Rotation Capacity** → How is that defined?
- Experiments / Simulations / Approximation formula

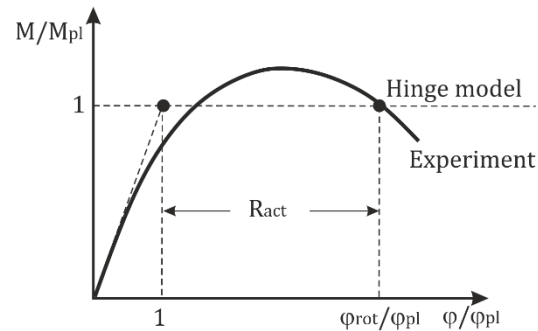
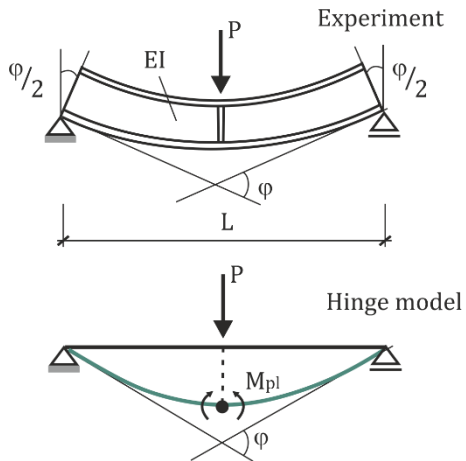

# Definition of Rotation Capacity

## Rotation Capacity

- Class 1 members of CSS show a sufficient **Rotation Capacity** → How is that defined?
- Experiments / Simulations / Approximation formula

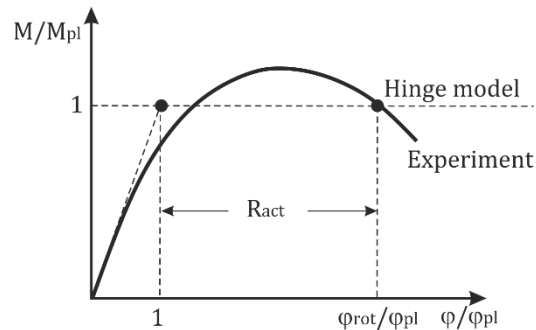
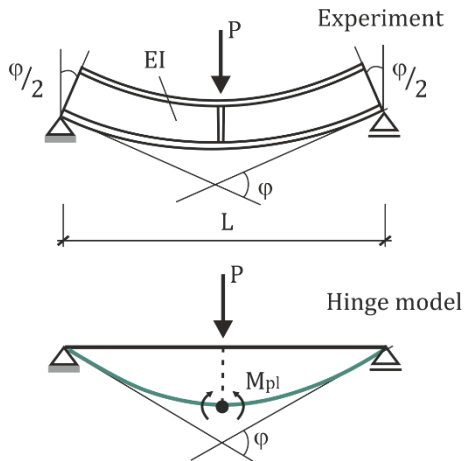

- The background of EC 3-1-1 used **R = 3** as requirement for Class 1
- Different systems require different rotation capacities **R**

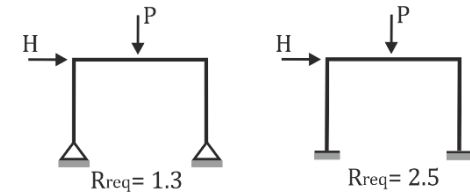

# Definition of Rotation Capacity

## Rotation Capacity

- Class 1 members of CSS show a sufficient **Rotation Capacity** → How is that defined?
- Experiments / Simulations / Approximation formula

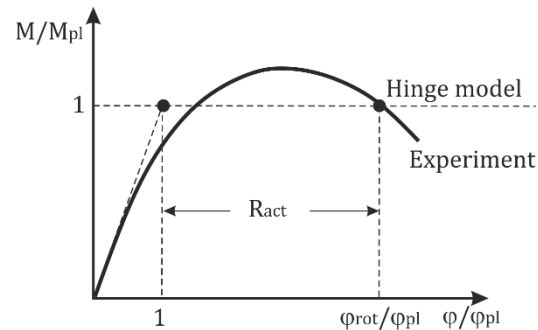
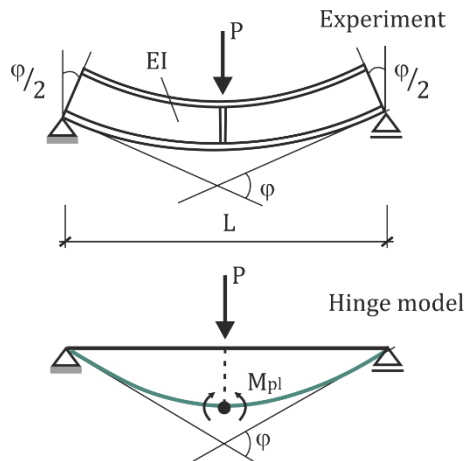

- The background of EC 3-1-1 used **R = 3** as requirement for Class 1
- Different systems require different rotation capacities **R**

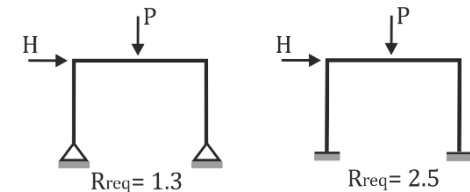

## High Strength Steels and Plastic Design EC 3-1-12 – Section 2.1 about 5.4.3

- Plastic global analysis is until now not allowed for steel grades over S460 to S700  
→ HSS are assumed to have too poor rotation capacities

# Experimental Investigations

Experimental rotation tests on beams: **HSS beams can own sufficient rotation capacity**

- 20 tests on I-shaped beams: 2 S355, 8 S690, 10 hybrid S690/S355
- Different slenderness properties ( $\frac{c}{t}$ ) and lengths

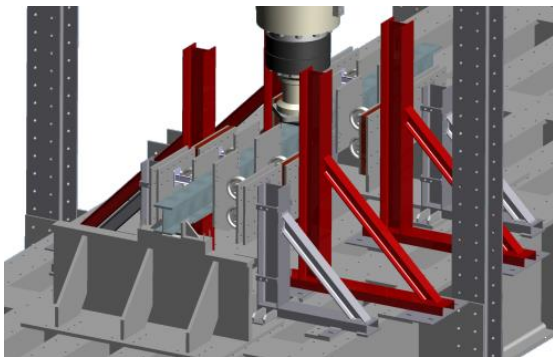
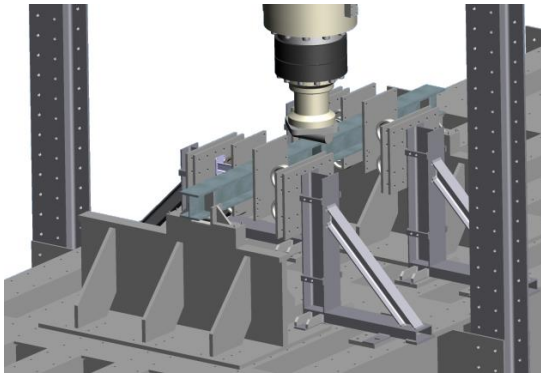

# Experimental Investigations

Experimental rotation tests on beams: **HSS beams can own sufficient rotation capacity**

- 20 tests on I-shaped beams: 2 S355, 8 S690, 10 hybrid S690/S355
- Different slenderness properties ( $\frac{c}{t}$ ) and lengths

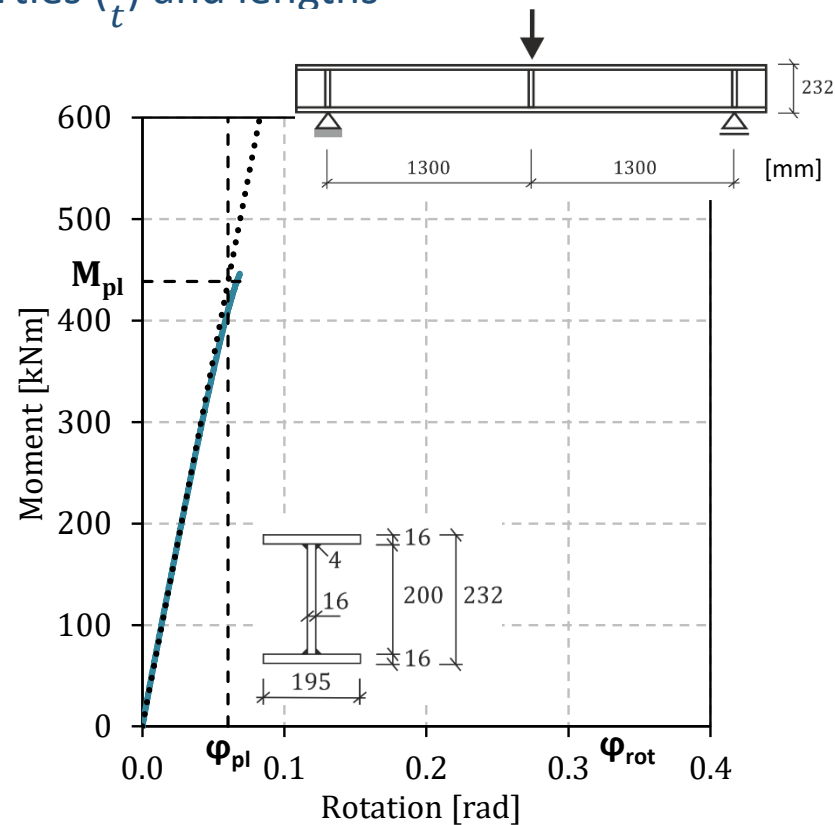
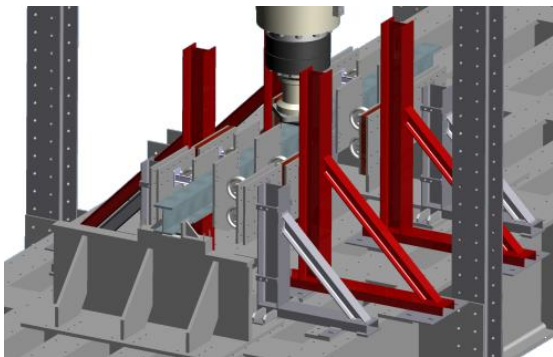
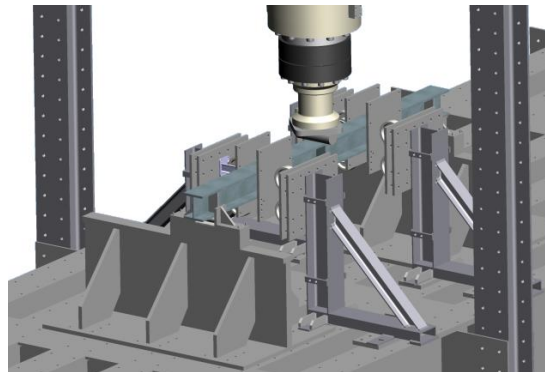

# Experimental Investigations

Experimental rotation tests on beams: **HSS beams can own sufficient rotation capacity**

- 20 tests on I-shaped beams: 2 S355, 8 S690, 10 hybrid S690/S355
- Different slenderness properties ( $\frac{c}{t}$ ) and lengths

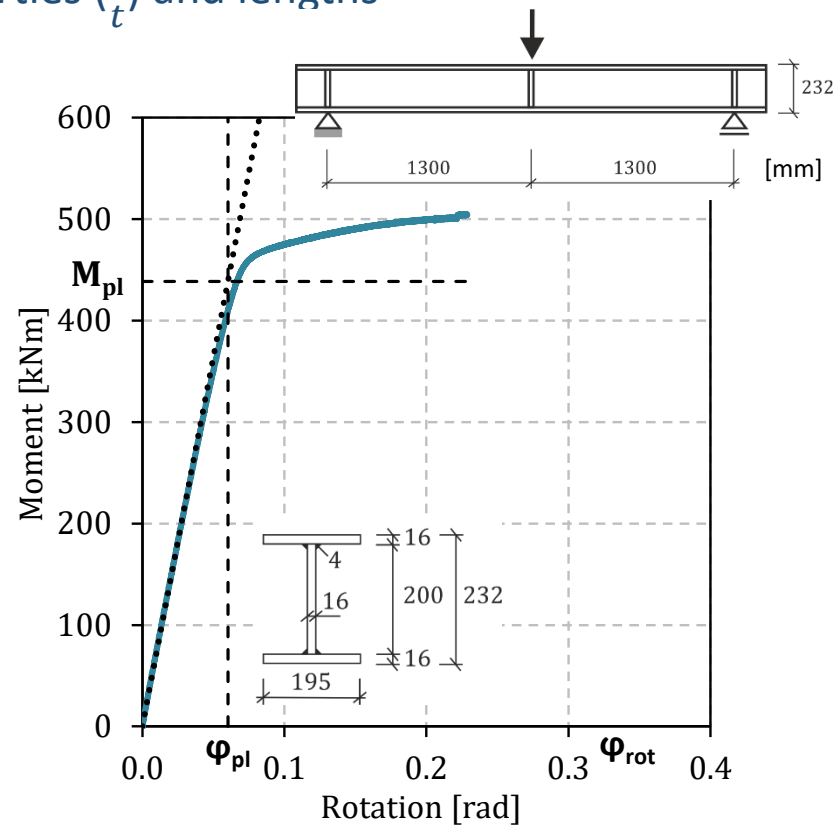
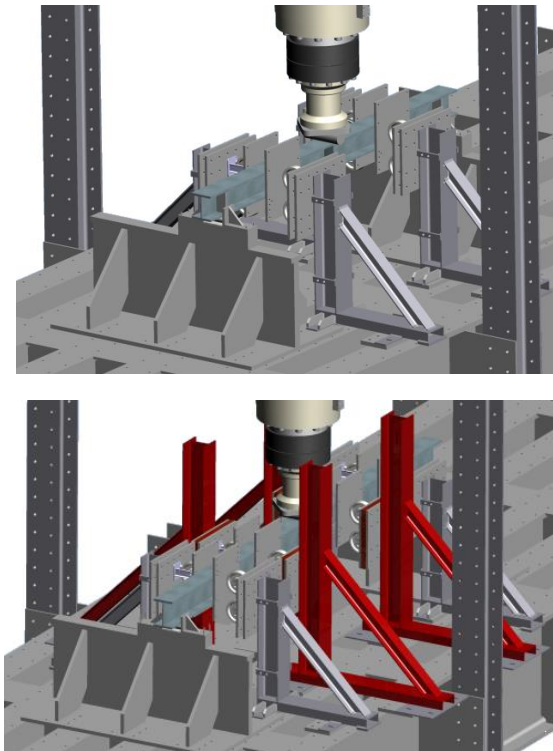

# Experimental Investigations

Experimental rotation tests on beams: **HSS beams can own sufficient rotation capacity**

- 20 tests on I-shaped beams: 2 S355, 8 S690, 10 hybrid S690/S355
- Different slenderness properties ( $\frac{c}{t}$ ) and lengths

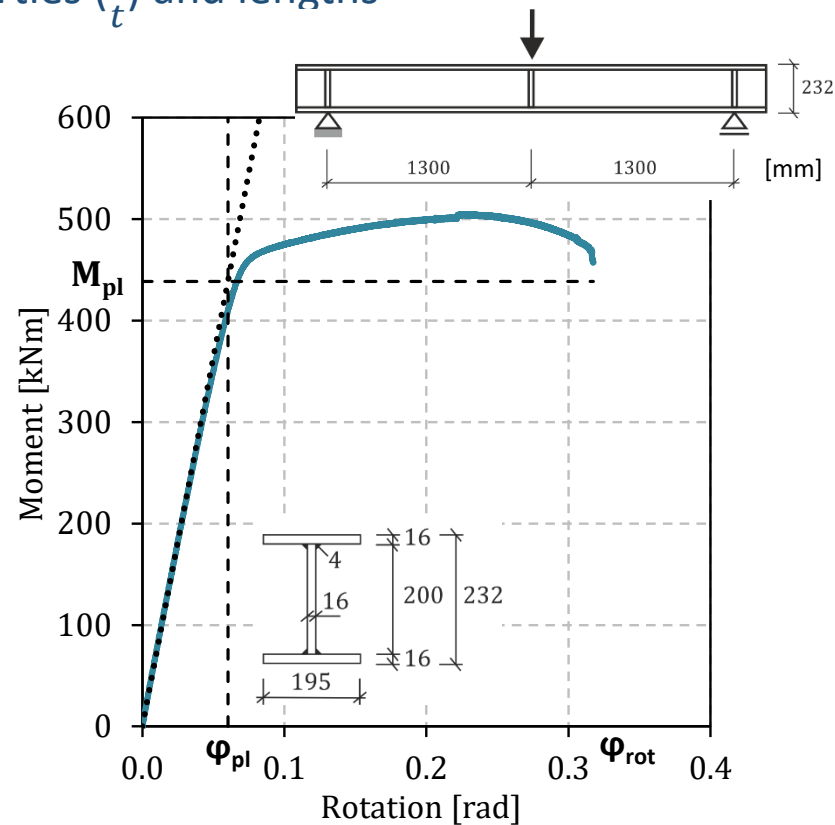
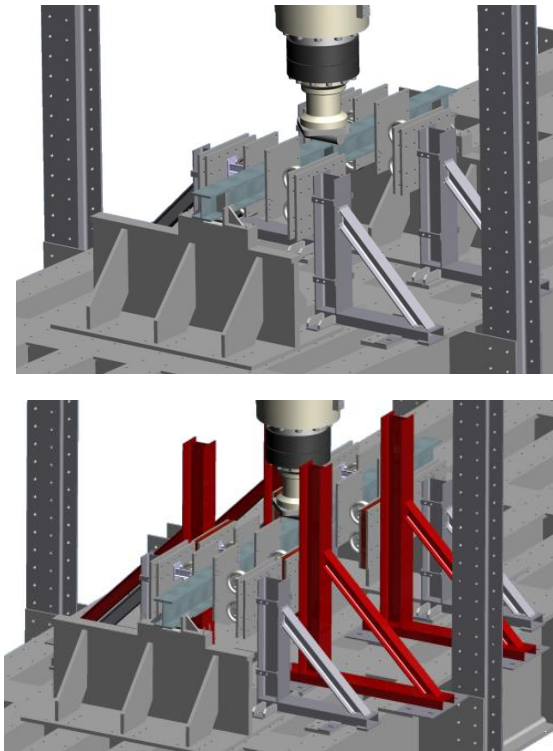

# Experimental Investigations

Experimental rotation tests on beams: **HSS beams can own sufficient rotation capacity**

- 20 tests on I-shaped beams: 2 S355, 8 S690, 10 hybrid S690/S355
- Different slenderness properties ( $\frac{c}{t}$ ) and lengths

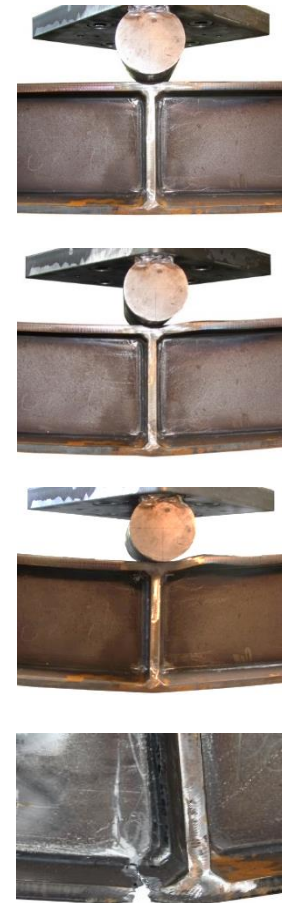
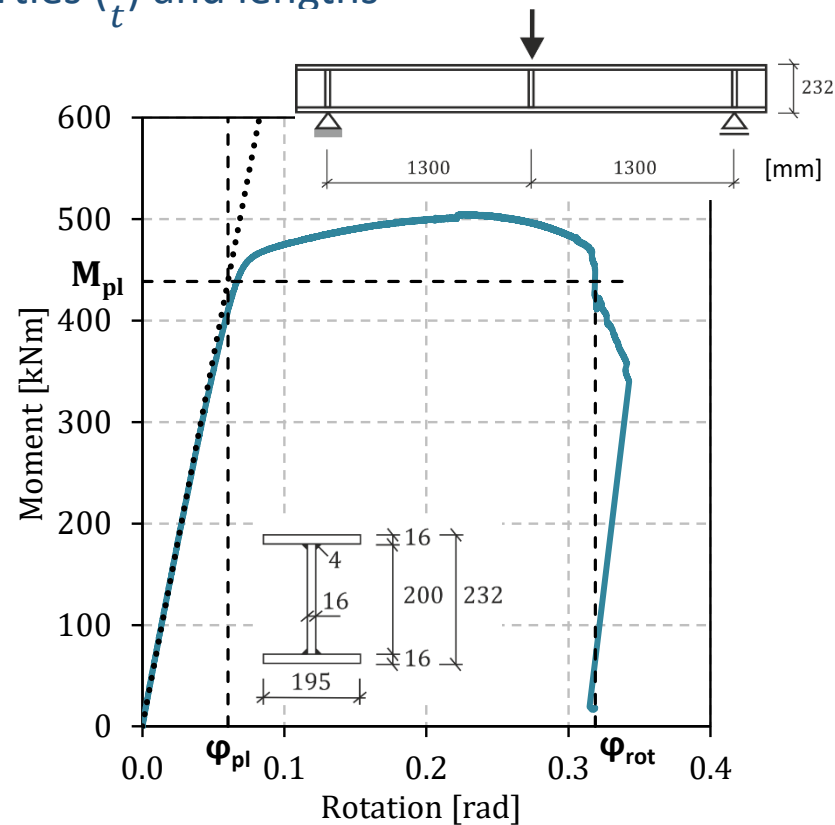
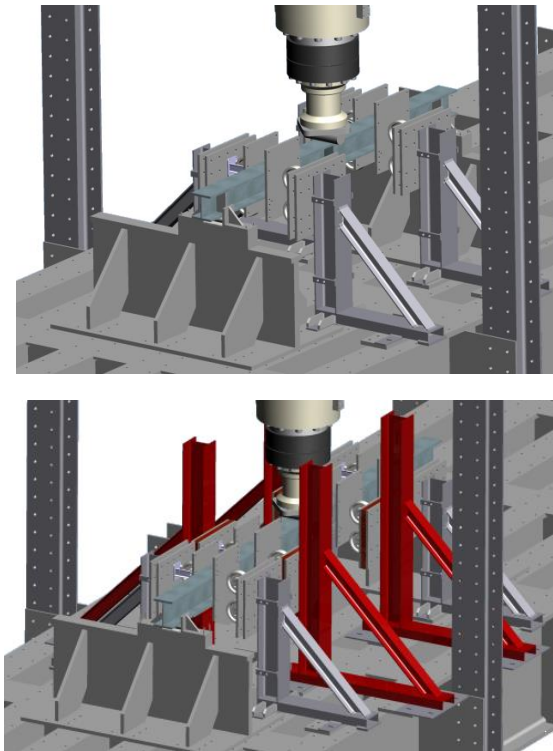

# Experimental Investigations

Experimental rotation tests on beams: **HSS beams can own sufficient rotation capacity**

- 20 tests on I-shaped beams: 2 S355, 8 S690, 10 hybrid S690/S355
- Different slenderness properties ( $\frac{c}{t}$ ) and lengths

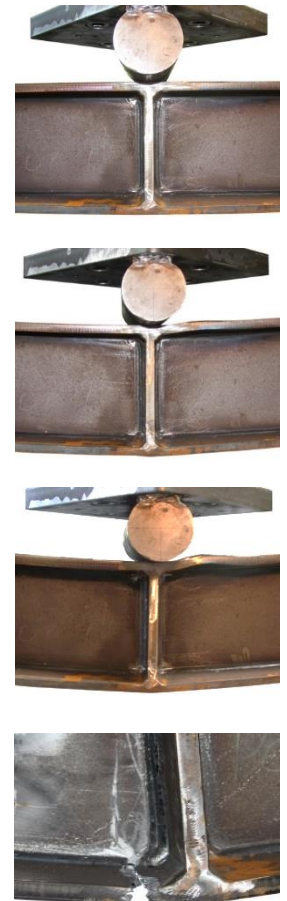
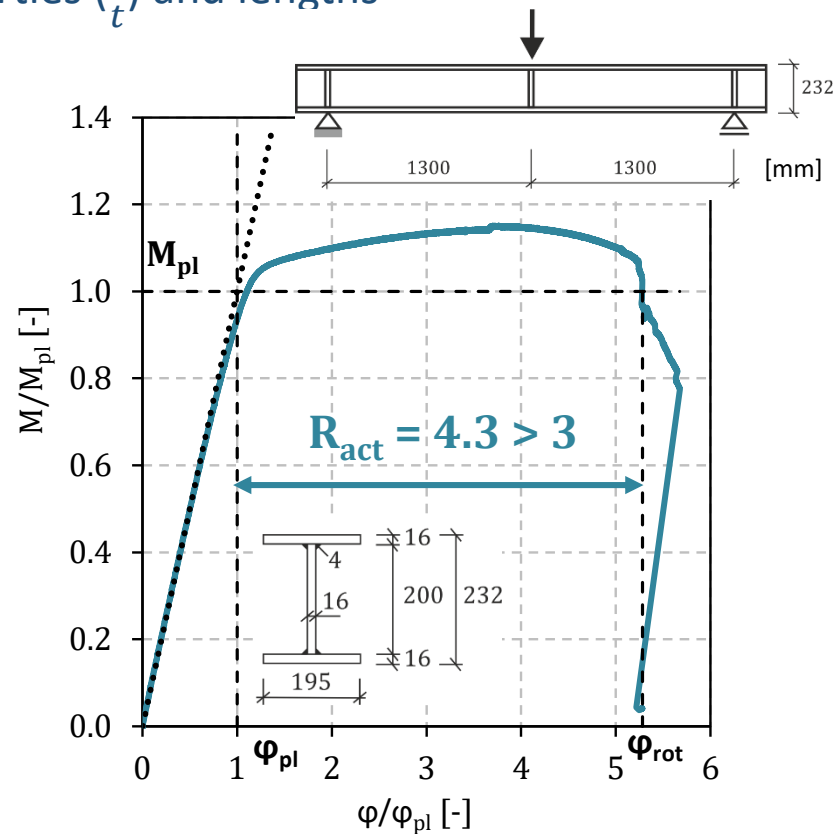
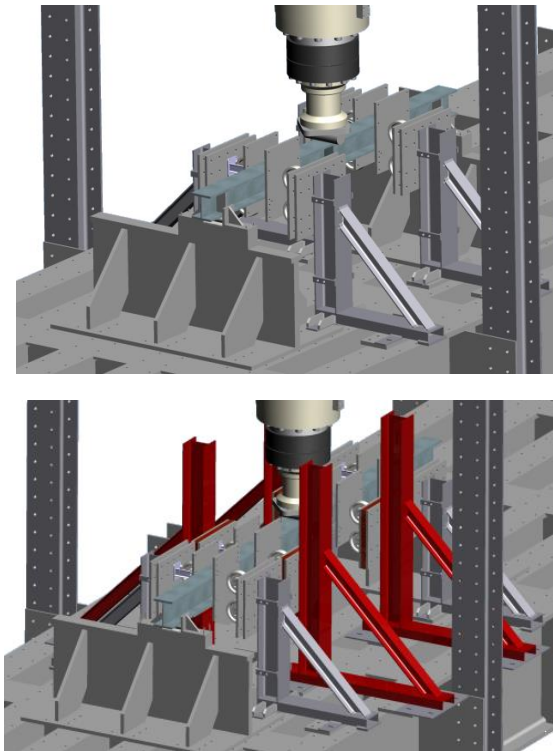

# Numerical Simulations

Numerical simulations of beams: **HSS beams can own sufficient rotation capacity**

- Simulations of tests with FE-models including plastic material and damage criterion

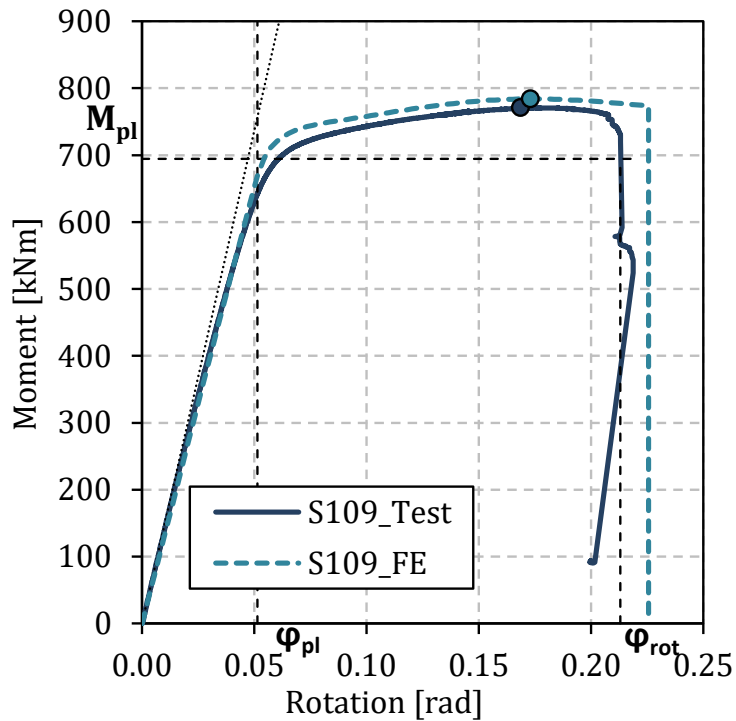

M- $\phi$  behaviour ✓

# Numerical Simulations

Numerical simulations of beams: **HSS beams can own sufficient rotation capacity**

- Simulations of tests with FE-models including plastic material and damage criterion

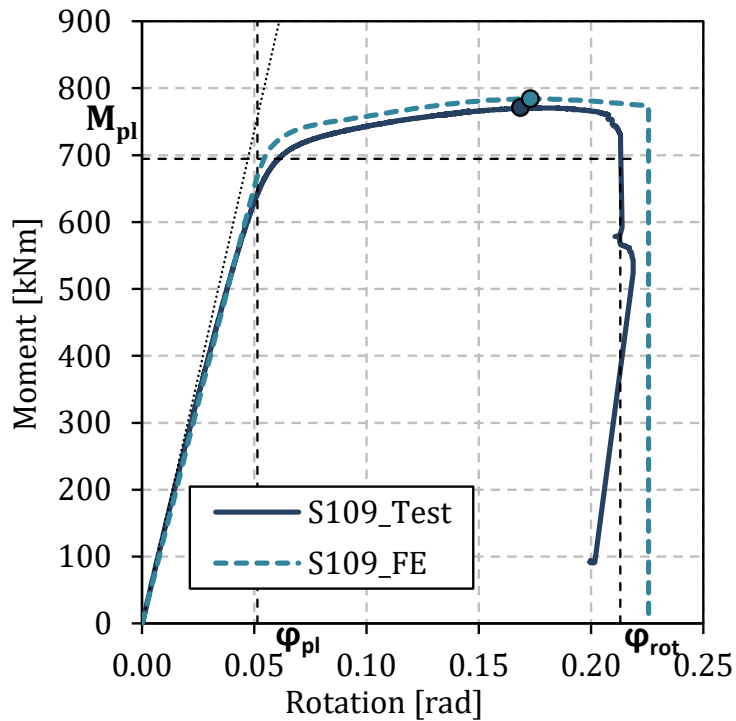

M- $\phi$  behaviour ✓

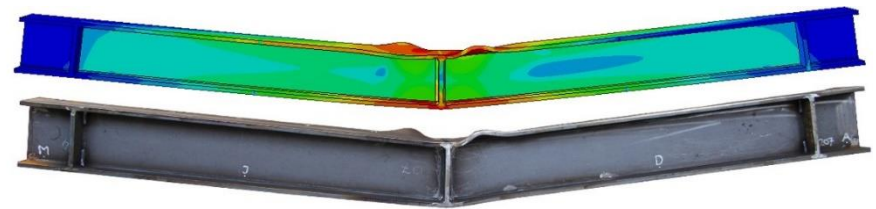
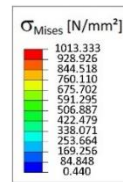

Deformation and local buckling ✓

# Numerical Simulations

Numerical simulations of beams: **HSS beams can own sufficient rotation capacity**

- Simulations of tests with FE-models including plastic material and damage criterion

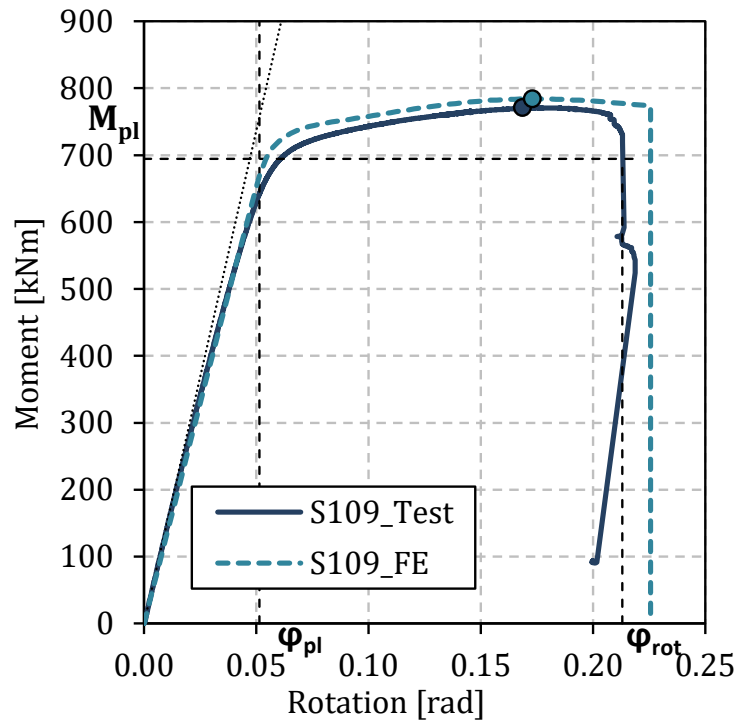

M- $\phi$  behaviour ✓

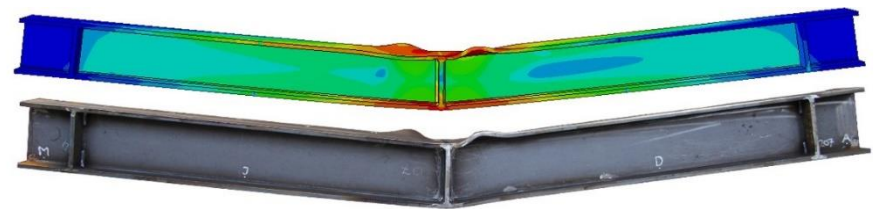
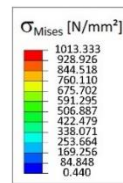

Deformation and local buckling ✓

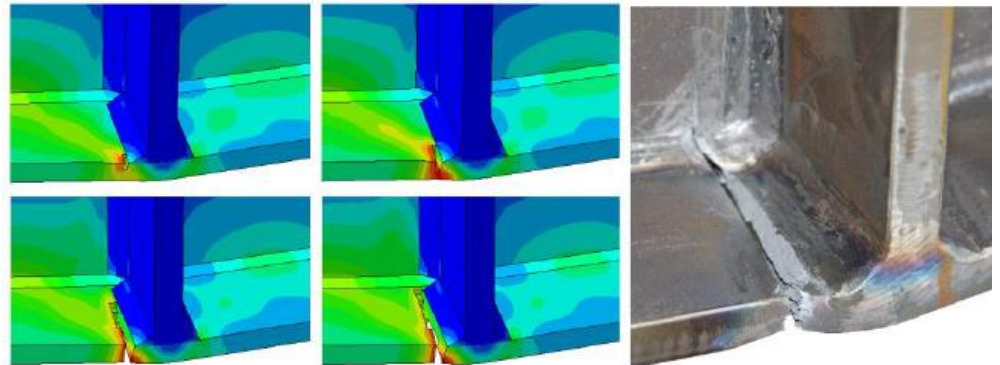

Crack initiation and growth ✓

# Numerical Simulations

Numerical simulations of beams: **HSS beams can own sufficient rotation capacity**

- Simulations of tests with FE-models including plastic material and damage criterion
- Parametric study: 780 Simulations

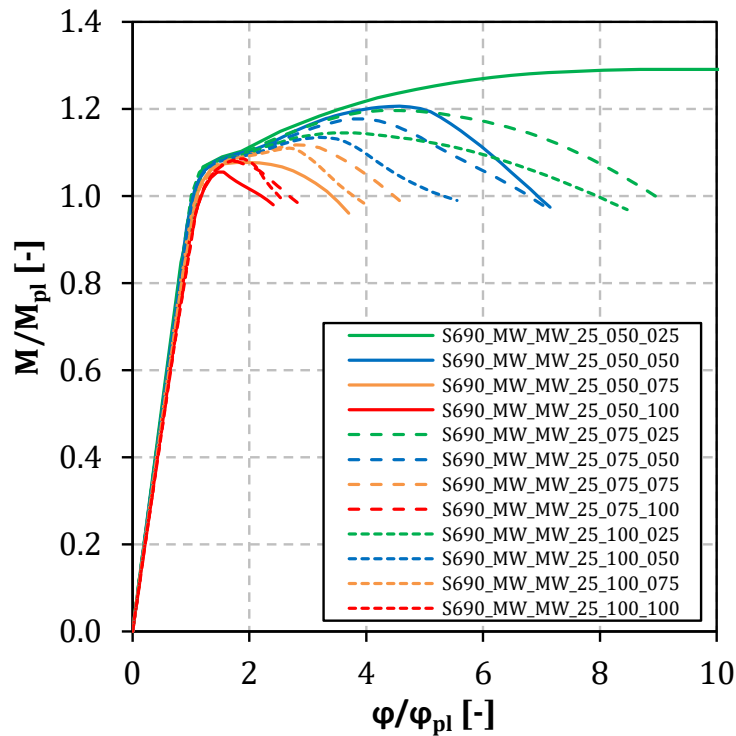

# Numerical Simulations

Numerical simulations of beams: **HSS beams can own sufficient rotation capacity**

- Simulations of tests with FE-models including plastic material and damage criterion
- Parametric study: 780 Simulations

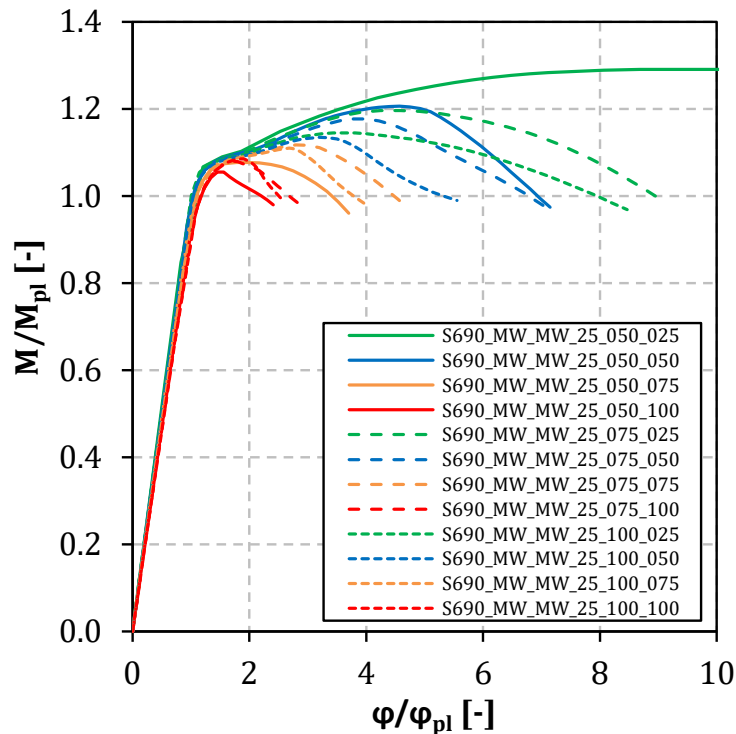

- Material: S500, S690
- 9 true stress strain curves per material
- 4 slenderness properties ( $\frac{c}{t}$ ) web
- 3 slenderness properties ( $\frac{c}{t}$ )
- Homogeneous and hybrid

# Outcome of Parametric Study

Influence of slenderness properties on Rotation Capacity:

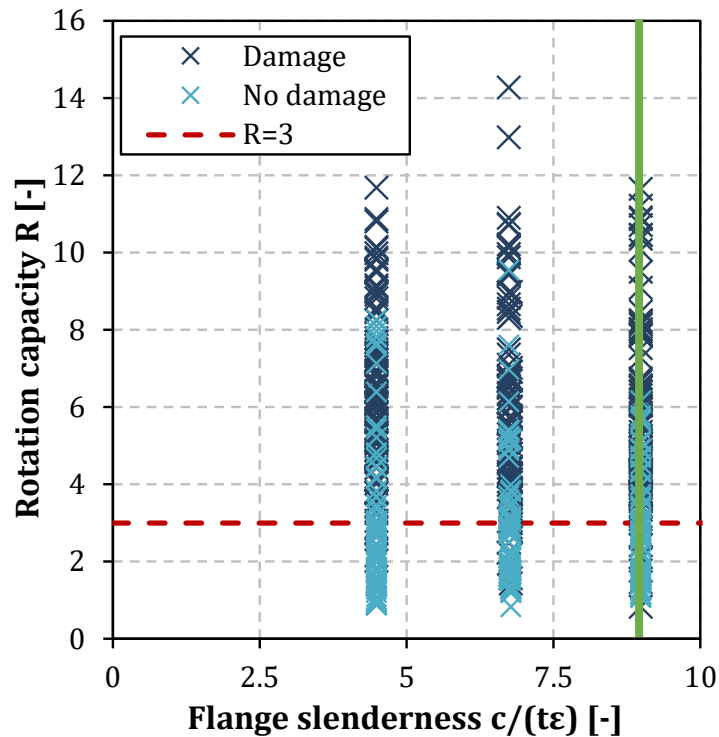

# Outcome of Parametric Study

Influence of slenderness properties on Rotation Capacity:

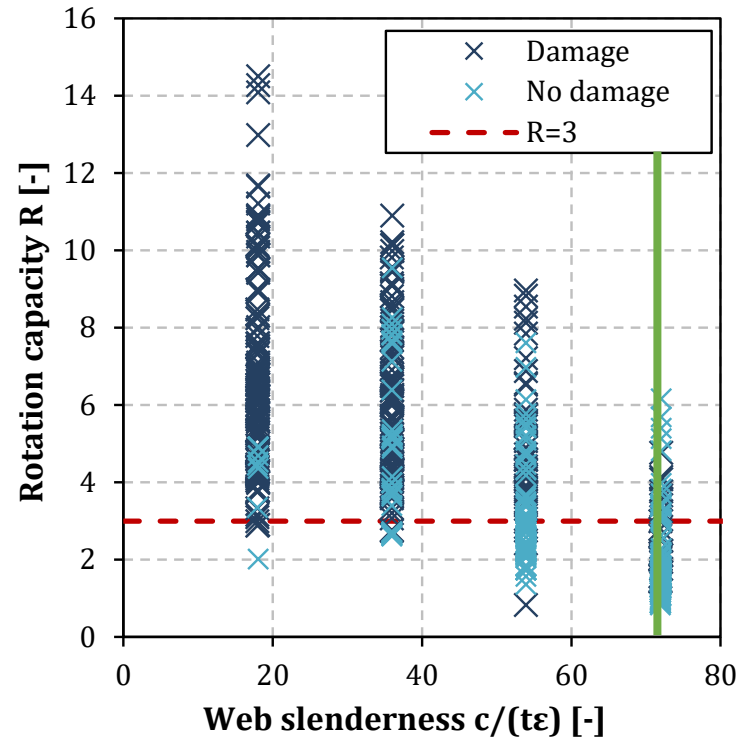
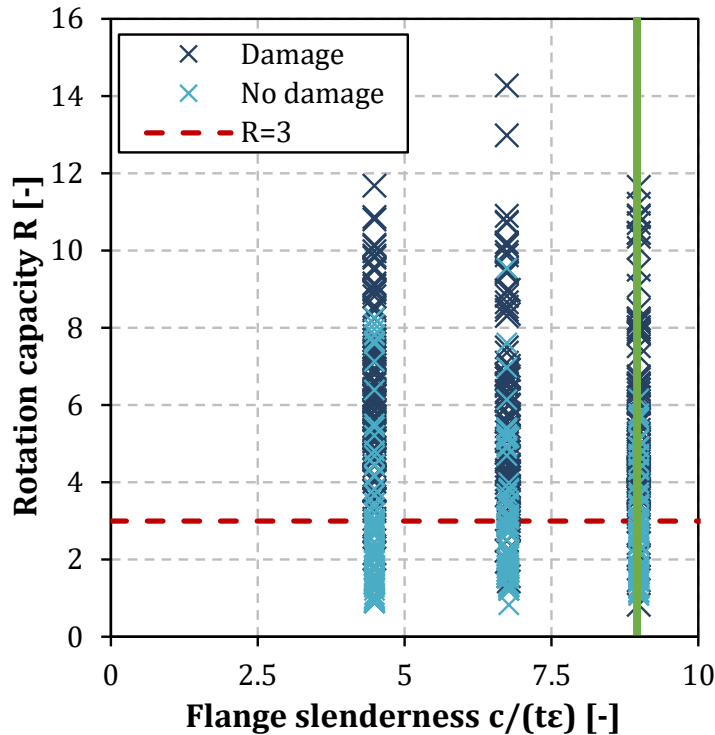

# Outcome of Parametric Study

Influence of slenderness properties on Rotation Capacity:

- Distinct influence of web slenderness

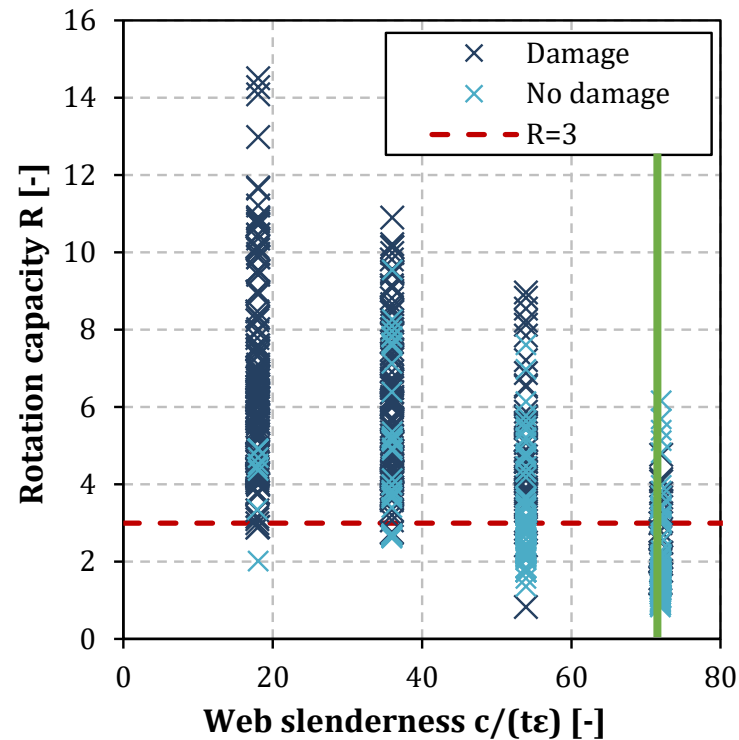
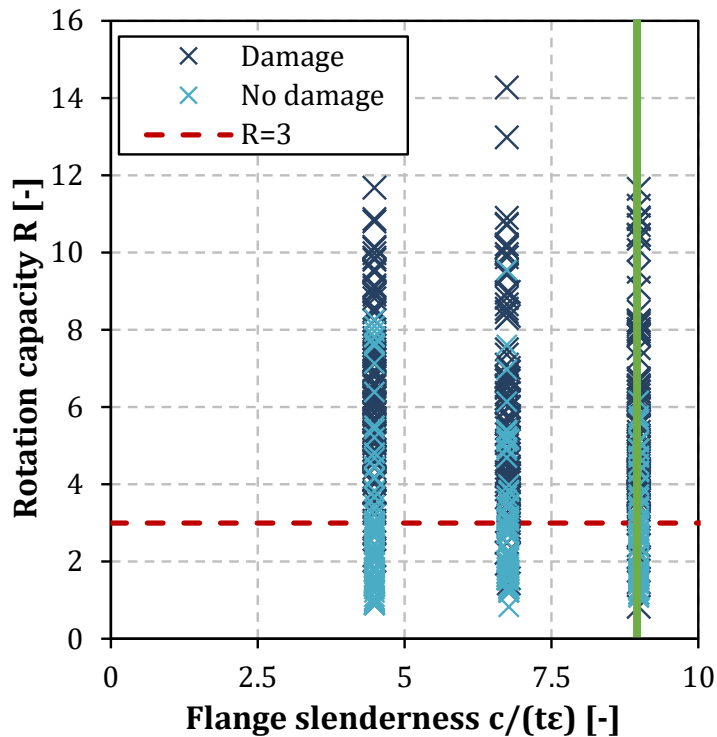



# Design Requirements

## Exemplary Approach: Stricter Class 1 limits for HSS

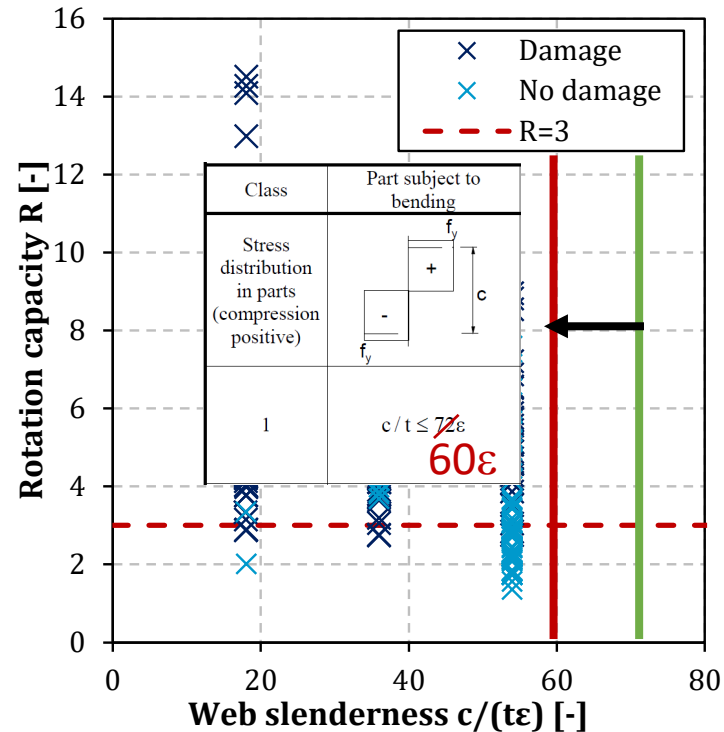
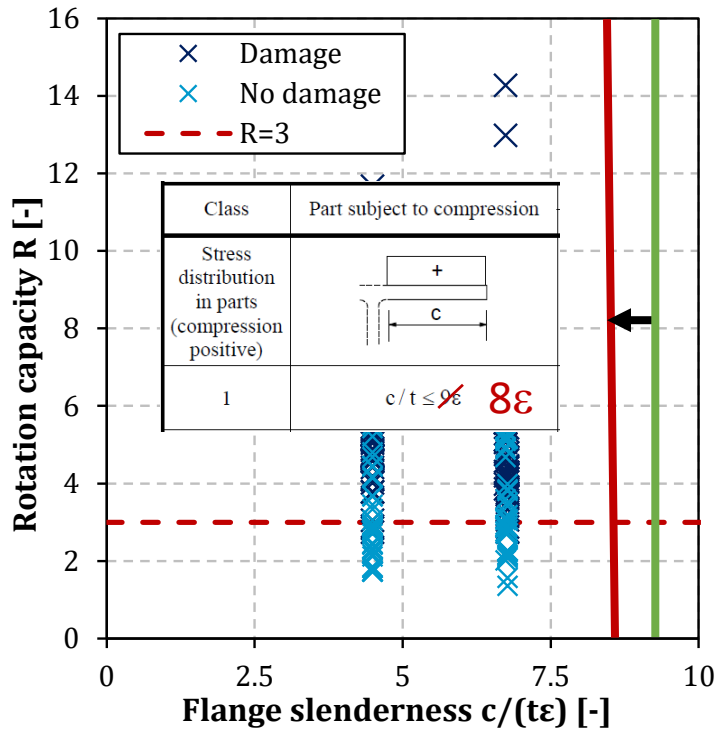
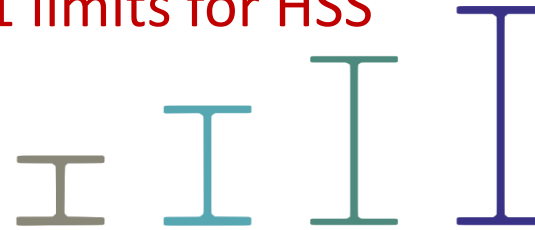

# Design Example

Designing a two-span beam with HSS using plastic design

$$P_{Ed} = 410 \text{ kN}$$

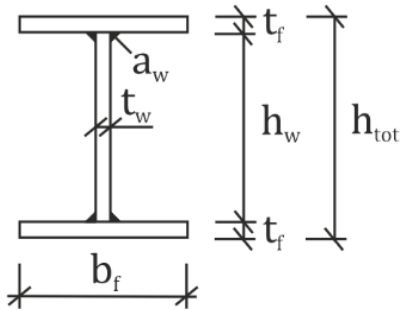

S690

$$b_f = 120 \text{ mm}$$

$$t_f = 12 \text{ mm}$$

$$h_w = 225 \text{ mm}$$

$$t_w = 10 \text{ mm}$$

$$a_w = 3 \text{ mm}$$

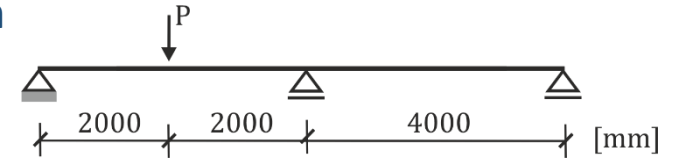

# Design Example

Designing a two-span beam with HSS using plastic design

$$P_{Ed} = 410 \text{ kN}$$

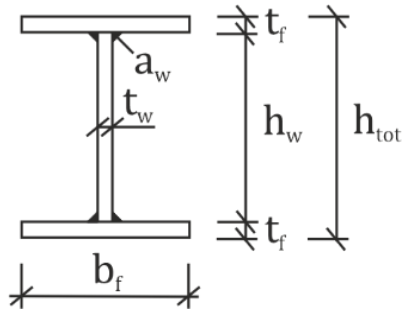

S690

$$b_f = 120 \text{ mm}$$

$$t_f = 12 \text{ mm}$$

$$h_w = 225 \text{ mm}$$

$$t_w = 10 \text{ mm}$$

$$a_w = 3 \text{ mm}$$

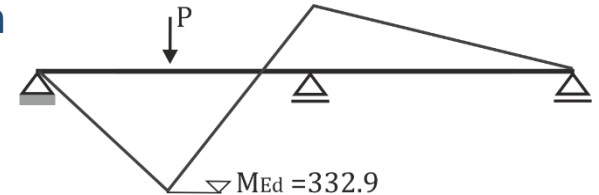

$$\text{Flange } \frac{c}{t \cdot \varepsilon} = 4.2 < 8 \rightarrow \text{Class 1}^*$$

$$\text{Web } \frac{c}{t \cdot \varepsilon} = 21.7 < 60 \rightarrow \text{Class 1}^*$$

# Design Example

Designing a two-span beam with HSS using plastic design

$$P_{Ed} = 410 \text{ kN}$$

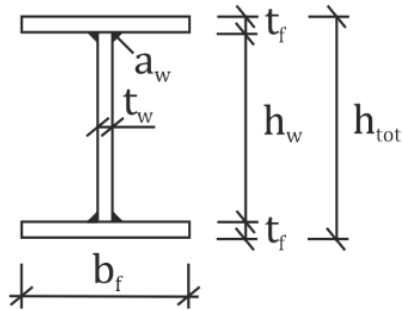

S690

$$b_f = 120 \text{ mm}$$

$$t_f = 12 \text{ mm}$$

$$h_w = 225 \text{ mm}$$

$$t_w = 10 \text{ mm}$$

$$a_w = 3 \text{ mm}$$

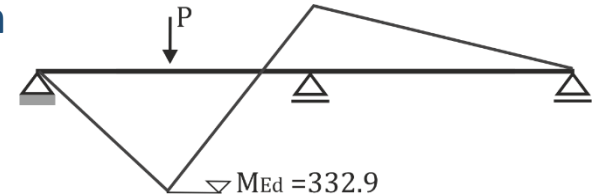

$$\text{Flange } \frac{c}{t \cdot \varepsilon} = 4.2 < 8 \rightarrow \text{Class 1}^*$$

$$\text{Web } \frac{c}{t \cdot \varepsilon} = 21.7 < 60 \rightarrow \text{Class 1}^*$$

$$M_{pl} = 276.9 \text{ kNm} < M_{Ed} = 332.9 \text{ kNm} \text{ (from elastic analysis)}$$

# Design Example

Designing a two-span beam with HSS using plastic design

$$P_{Ed} = 410 \text{ kN}$$

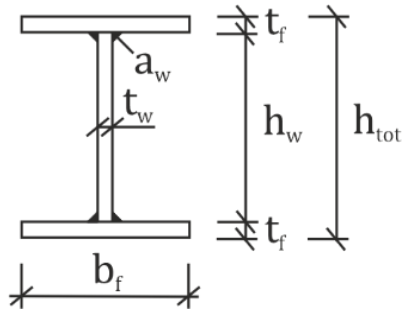

S690

$$b_f = 120 \text{ mm}$$

$$t_f = 12 \text{ mm}$$

$$h_w = 225 \text{ mm}$$

$$t_w = 10 \text{ mm}$$

$$a_w = 3 \text{ mm}$$

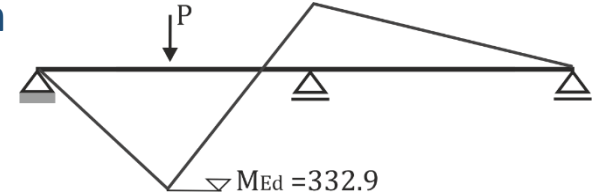

$$\text{Flange } \frac{c}{t \cdot \varepsilon} = 4.2 < 8 \rightarrow \text{Class 1}^*$$

$$\text{Web } \frac{c}{t \cdot \varepsilon} = 21.7 < 60 \rightarrow \text{Class 1}^*$$

$$M_{pl} = 276.9 \text{ kNm} < M_{Ed} = 332.9 \text{ kNm} \text{ (from elastic analysis)}$$

→ Plastic Design necessary

# Design Example

Designing a two-span beam with HSS using plastic design

$$P_{Ed} = 410 \text{ kN}$$

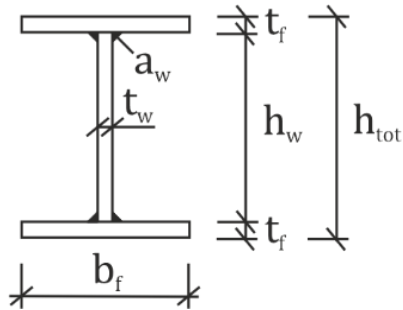

S690

$$b_f = 120 \text{ mm}$$

$$t_f = 12 \text{ mm}$$

$$h_w = 225 \text{ mm}$$

$$t_w = 10 \text{ mm}$$

$$a_w = 3 \text{ mm}$$

$$\text{Flange } \frac{c}{t \cdot \epsilon} = 4.2 < 8 \rightarrow \text{Class 1*}$$

$$\text{Web } \frac{c}{t \cdot \epsilon} = 21.7 < 60 \rightarrow \text{Class 1*}$$

$$M_{pl} = 276.9 \text{ kNm} < M_{Ed} = 332.9 \text{ kNm}$$

→ Plastic Design necessary

$$P_{pl}^{el} = 341 \text{ kN (First order elastic analysis)}$$

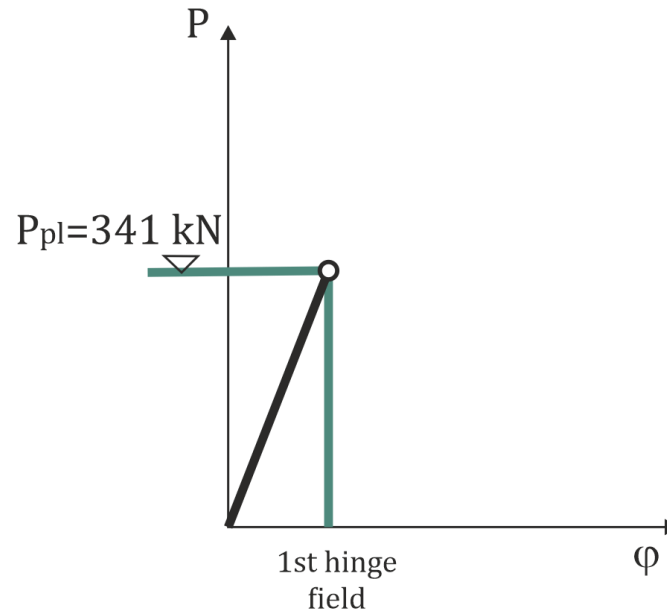
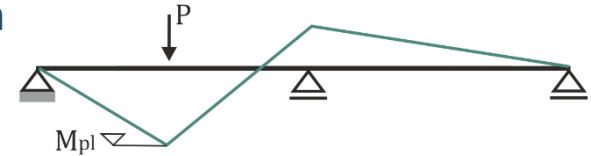

# Design Example

Designing a two-span beam with HSS using plastic design

$$P_{Ed} = 410 \text{ kN}$$

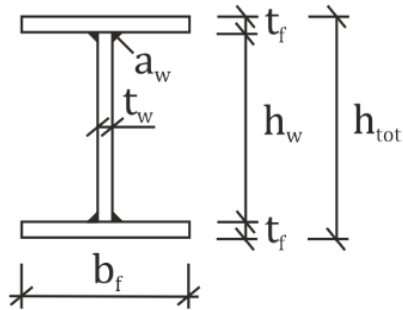

S690

$$b_f = 120 \text{ mm}$$

$$t_f = 12 \text{ mm}$$

$$h_w = 225 \text{ mm}$$

$$t_w = 10 \text{ mm}$$

$$a_w = 3 \text{ mm}$$

$$\text{Flange } \frac{c}{t \cdot \epsilon} = 4.2 < 8 \rightarrow \text{Class 1}^*$$

$$\text{Web } \frac{c}{t \cdot \epsilon} = 21.7 < 60 \rightarrow \text{Class 1}^*$$

$$M_{pl} = 276.9 \text{ kNm} < M_{Ed} = 332.9 \text{ kNm}$$

→ Plastic Design necessary

$$P_{pl}^{el} = 341 \text{ kN} \text{ (First order elastic analysis)}$$

$$P_{pl}^{pl} = 341 \text{ kN} + 74 \text{ kN} = 415 \text{ kN} > 410 \text{ kN}$$

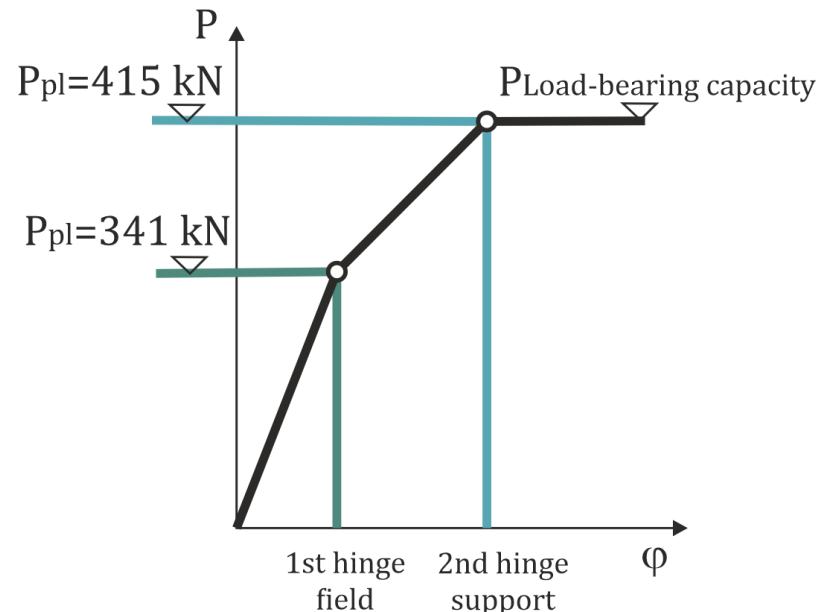
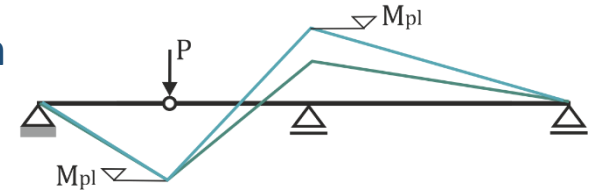

# Design Example

Using S355:

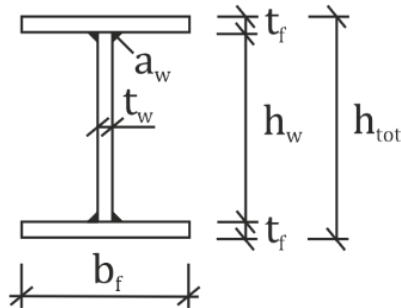

S690 → S355       $P_{Ed} = 410 \text{ kN}$

$b_f = 120 \text{ mm} \rightarrow 135 \text{ mm}$   
 $t_f = 12 \text{ mm} \rightarrow 15 \text{ mm}$   
 $h_w = 225 \text{ mm} \rightarrow 300 \text{ mm}$   
 $t_w = 10 \text{ mm} \rightarrow 12 \text{ mm}$   
 $a_w = 3 \text{ mm} \rightarrow 4 \text{ mm}$

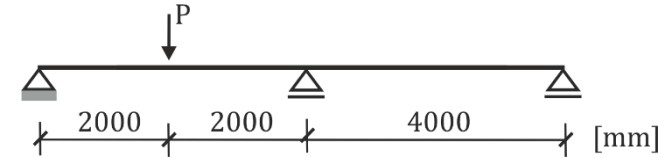

Flange  $\frac{c}{t \cdot \varepsilon} = 4.2 < 8 \rightarrow \text{Class 1} \rightarrow 3.7 < 9 \rightarrow \text{Class 1}$

Web  $\frac{c}{t \cdot \varepsilon} = 21.7 < 60 \rightarrow \text{Class 1} \rightarrow 24.1 < 72 \rightarrow \text{Class 1}$

$M_{pl} = 276.9 \text{ kNm} \rightarrow 274.4 \text{ kNm} < M_{Ed} = 332.9 \text{ kNm}$

→ Plastic Design necessary

$P_{pl}^{el} = 341 \text{ kN} \rightarrow 338 \text{ kNm}$

$P_{pl}^{pl} = 341 \text{ kN} + 74 \text{ kN} = 415 \text{ kN} \rightarrow 338 \text{ kN} + 74 \text{ kN} = 412 \text{ kN} > 410 \text{ kN}$

# Design Example

Using S355:

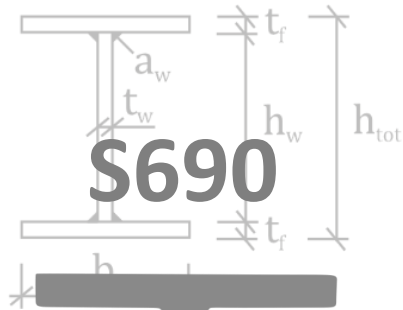

**S690**

**S355**  $P_{Ed} = 410 \text{ kN}$

S690 → S355  
 $b_f = 120 \text{ mm} \rightarrow 125 \text{ mm}$   
 $t_f = 12 \text{ mm} \rightarrow 15 \text{ mm}$   
 $h_w = 225 \text{ mm} \rightarrow 300 \text{ mm}$   
 $t_w = 10 \text{ mm} \rightarrow 12 \text{ mm}$   
 $a_w = 3 \text{ mm} \rightarrow 4 \text{ mm}$



Flange  $\frac{c}{t \cdot \epsilon} = 4.2 < 8 \rightarrow \text{Class 1} \rightarrow 3 < 9 \rightarrow \text{Class 1}$

Web  $\frac{c}{t \cdot \epsilon} = 21.7 < 60 \rightarrow \text{Class 1} \rightarrow 24.1 < 72 \rightarrow \text{Class 1}$

$M_{pl} = 216.9 \text{ kNm} \rightarrow 274.4 \text{ kNm} < M_{Ed} = 332.9 \text{ kNm}$

→ Plastic Design necessary

$P_{pl}^{el} = 341 \text{ kN} \rightarrow 338 \text{ kN}$

$P_{pl}^{pl} = 341 \text{ kN} + 74 \text{ kN} = 415 \text{ kN} \rightarrow 338 \text{ kN} + 74 \text{ kN} = 412 \text{ kN} > 410 \text{ kN}$

Use of S355 instead of S690  
 → **50% more weight**

Additional checks needed  
 e.g. Deformation limits

# Conclusions

- **Plastic Design** - Realistic determination of load bearing capacity

→ Economic design

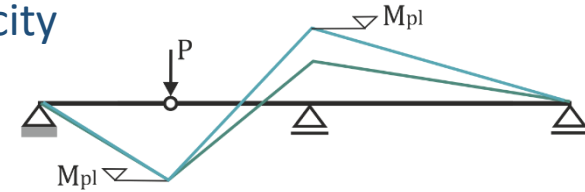

# Conclusions

- **Plastic Design** - Realistic determination of load bearing capacity  
→ Economic design
- Rotation capacity depends on various influencing factors
- High strength steel can own sufficient rotation capacity

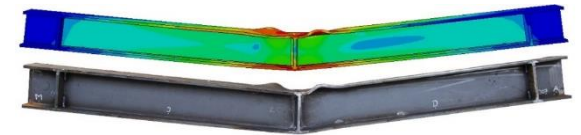
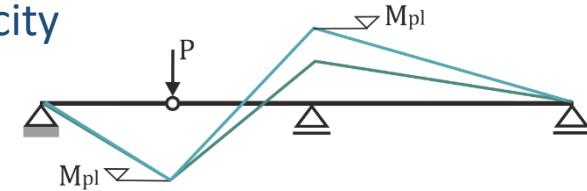

# Conclusions

- **Plastic Design** - Realistic determination of load bearing capacity

→ Economic design

- Rotation capacity depends on various influencing factors
- High strength steel can own sufficient rotation capacity
- Limitations for plastic design with HSS are necessary

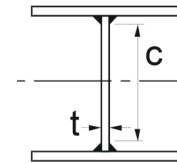
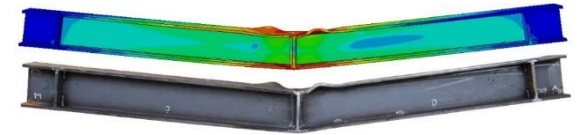
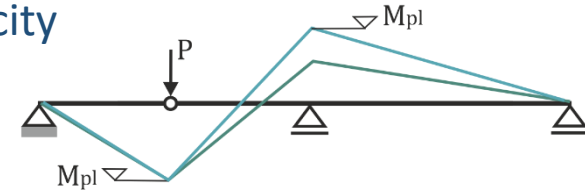

Class	Part subject to bending
Stress distribution in parts (compression positive)	<p>Stress distribution in parts (compression positive)</p>
1	$c/t \leq 7\epsilon$



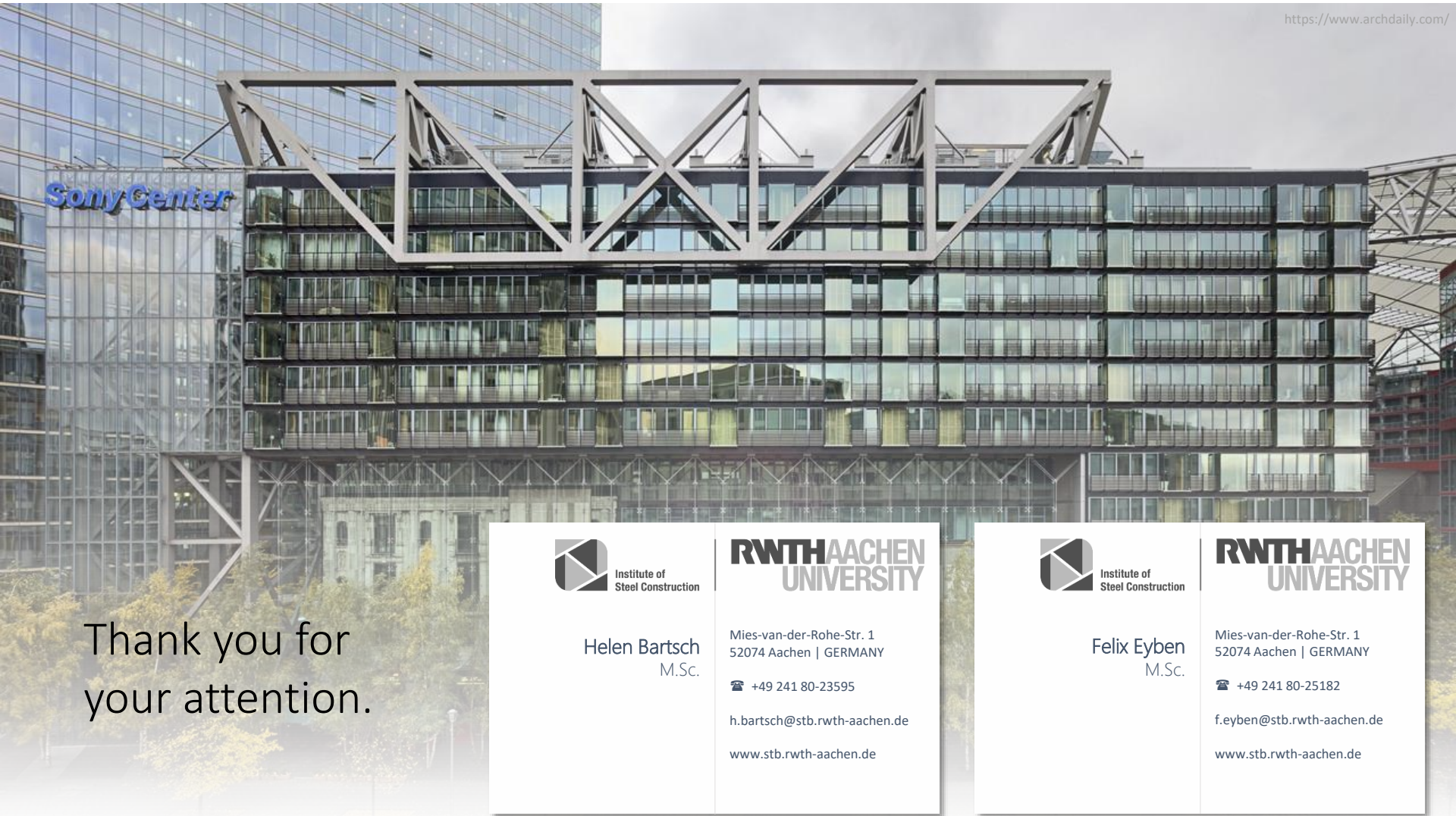

Thank you for  
your attention.



Institute of  
Steel Construction

Helen Bartsch  
M.Sc.

**RWTHAACHEN**  
UNIVERSITY

Mies-van-der-Rohe-Str. 1  
52074 Aachen | GERMANY

+49 241 80-23595

[h.bartsch@stb.rwth-aachen.de](mailto:h.bartsch@stb.rwth-aachen.de)

[www.stb.rwth-aachen.de](http://www.stb.rwth-aachen.de)



Institute of  
Steel Construction

Felix Eyben  
M.Sc.

**RWTHAACHEN**  
UNIVERSITY

Mies-van-der-Rohe-Str. 1  
52074 Aachen | GERMANY

+49 241 80-25182

[f.eyben@stb.rwth-aachen.de](mailto:f.eyben@stb.rwth-aachen.de)

[www.stb.rwth-aachen.de](http://www.stb.rwth-aachen.de)